



Specifications

Application: Urban roads and street , Squares areas, Pedestrian areas, Residential areas,Parks

Installing Hight: 3-5m

Mounting : Post-top: suitable for Ø60mmx55mm tenon

Lamps: HID (HPS MH)/ LED bulb / CFL lamps, 30W-150W

70W/150W HPS high pressure sodium, cap: E27/E26/E40/E39

70W/150W MH metal halide, cap: E27/E26/E40/E39

20W/30w/50W Led bulb or mouldle, cap: E27/E26

35W/45W/65W Compact fluorescent, cap: E27/E26

Input Voltage: 90-270VAC,50-60HZ

Material: Aluminium body

Housing: Heavy-duty die cast aluminium, Powder coating

Lens : Clear or texture glass, clear arcylic is optional.

Color: Standard color are Black, Yellow metal or Red metal ,other colors are available

Standards:

Isolation degree Class I, IP Rating IP54



Black yellow-metal red-metal

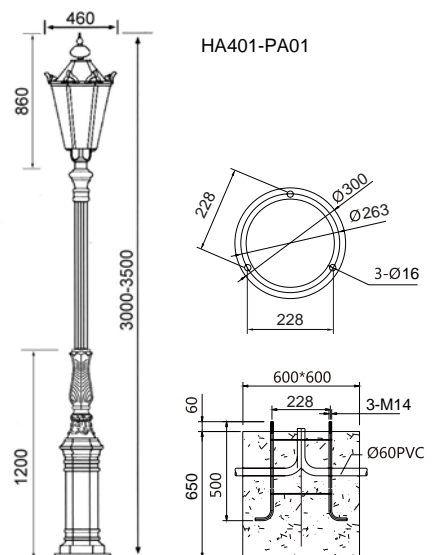

Ordering Information

Order No.	Lamp Wattage	Lamp Socket	Install Height	Gross/ Net Weight	Dimension L*W*H(cm)	Packing size(cm)	QTY(pcs) 20'/40'GP
Head HA401	MAX 150W	E27/E40	3m-5m	9 / 8kg	46x40x86	46x41x58	240/480
HA401-PA01-2.1	MAX 150W	E27/E40	3m	22 /21kg	46x40x86 30x30x210	46x41x58 30x30x210	100/ 200
HA401-PA01-2.6	MAX 150W	E27/E40	3.5m	25 /24kg	46x40x86 30x30x260	46x41x58 30x30x260	90/ 180
HA401-PA01-3.1	MAX 150W	E27/E40	4m	30 /29kg	46x40x86 30x30x310	46x41x58 30x30x310	50/ 150